



# NAVIGATION TRAINING

ANGEL OFFROAD TRAINING

# RALLY JAMEEL

Rally Jameel is a Navigation Rally

## GOAL

Collect waypoints using roadbook and GPS to find the right way using :

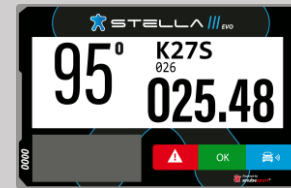
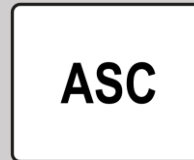
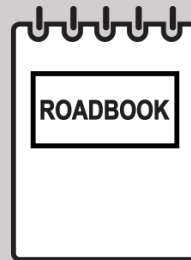

# ROAD BOOK

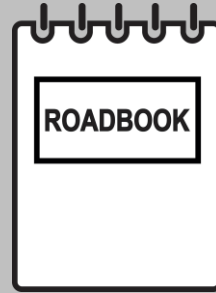









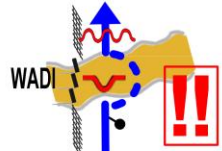

# ROADBOOK

A road book is a detailed description of a route to follow in table form.

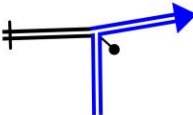
Reading direction is top to bottom

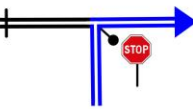
Each line describes a significant point of the stage as :

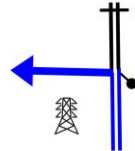
- Cross roads
- change of direction
- Dangerous points...



4		RALLY JAMEEL / DAY 2 / SS2 QASSIM	Km : 94,44
<u>18,80</u>			
1,44			
<u>19,94</u>			
1,14			
<u>20,03</u>			
0,09			
<u>22,40</u>			
2,37			
<u>22,63</u>			
0,23			

Next 1,25

**Danger 2**

# HOW IS IT MADE ?

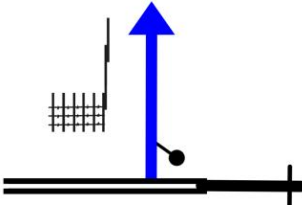
The road book is made up of rows and columns. Each row contains three columns.

1	RALLY JAMEEL / DAY 2 / SS2 QASSIM	Km : 94,44
0,00		 DSS
0,00		(16)

Partial and  
total mileage

Graphical representation of  
where you are and showing  
the direction to follow.

Other information

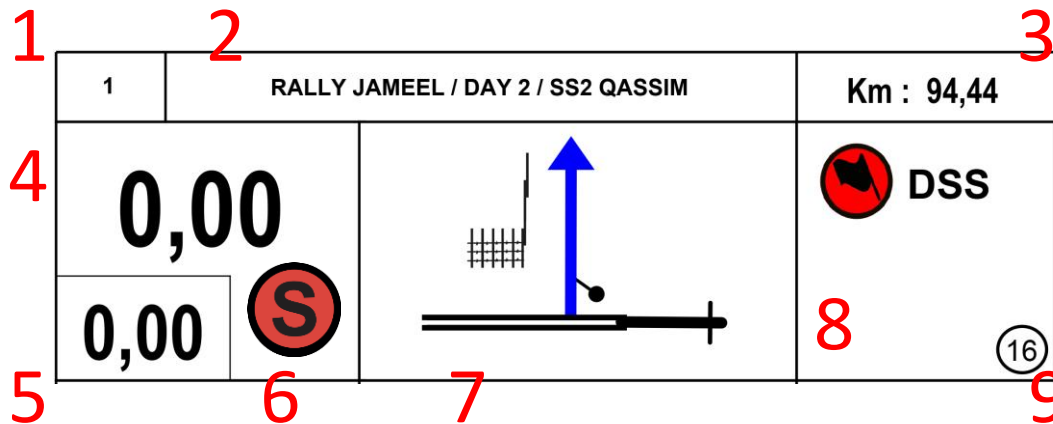

1	Roadbook page number
2	Roadbook header with stage number / name
3	Total kilometers from the start to the finish
4	Total kilometer at the corresponding diagram box
5	Partial kilometer from previous diagram box

6	Placeholder for waypoint icon
7	Graphic information
8	Description box
9	Placeholder for waypoint number <i>Here : waypoint 16 (DSS)</i>

# WAYPOINTS

WAYPOINTS	
<b>M</b>	Masked WP
<b>C</b>	Control WP
<b>S</b>	Security WP
<b>N</b>	Navigation WP
<b>P</b>	Precise WP
<b>V</b>	Visible WP
<b>E</b>	Eclipse WP
<b>1</b>	Waypoint number

	Waypoint	Opening Radius	Validation Radius in metres
Navigation WP	WPE	Prev (1000 m)	90
	WPN	800 m	200
	WPM	800 m	90
	WPS	1000 m	30
	WPC	None	300
	WPP	100 m	20
	CP	Prev (1000 m)	90
Start/Finish/Zone WP	WPV	Open	200
	DSS	Prev (1000 m)	200
	ASS	800 m	90
	DZ	1000 m (Prev)	90
	FZ	Prev (1000 m)	90
	DN/DT	1000 m (Prev)	90
	FN/FT	Prev (1000 m)	90

Prev (1000 m) = previous waypoint or within a radius of 1000 m if the previous waypoint was missed

1000 m (Prev) = within a radius of 1000 m or previous waypoint, whichever distance is shorter.

# ROADBOOK SYMBOLS

TRACKS	WAYPOINTS	ON TRACK	SYMBOLS
Tarmac road	Masked WP	Bump	Fence
Track Piste	Control WP	Dip hole	Barbed fence
Off track (HP)	Security WP	Compression	Rail road
Low visible track / traces	Navigation WP	Ditch	Hole
<b>P</b> Track Piste	Precise WP	Summit	Collapse, ditch, ravine, etc.
<b>PP</b> Principal track/ piste	Visible WP	Above bridge	Ruts
<b>RO</b> Road	Eclipse WP	Under bridge	Twisty / sinuous
<b>P//</b> Parallel track/piste	Waypoint number	Step up	Bumpy / broken
<b>HP</b> Off track (Sight driving!)	<b>CONTROLS</b>	Step down	Bumpy
<b>HP</b> Off track forbidden	Start Selective Section	Up hill	Lateral inclination
<b>FPP</b> Follow principal track/piste	Arrival Selective Section	Down hill	Post
<b>FRO</b> Follow road	Check point	Cut danger	Electric pole
<b>SA</b> Sandy	Start/Finish Neutralisation	Right or left over crest	Electric line
<b>GV</b> Gravel	Start neutralisation with speed limit	Fence with cattle gate	High voltage tower
<b>SAFETY</b>	Start/Finish Transfer	Wall gate	Antenna
Danger Level 1	Start transfer with speed limit	Wading / water cross	Well
Danger Level 2	Neut./transfer max. time allowed	Concrete pass	Tanks
Danger Level 3	Waiting for restart	<b>CAPS</b>	Barrels
Global danger in the note	Stop for restart	Exit cap	Notable elements
Start Speed limit	Fuel zone with authorized cal.	Average cap	Tires
Finish Speed limit	Time control	Calculated cap (only HP)	Sign posts
Stop	Assistance Service	Cap that turns	Restricted/protected area
Important	Tyre marking zone	Buildings / houses	Church / mosque
Red line under km = danger 2 in the note	End zone		

SYMBOLS	SYMBOLS	ABBREVIATIONS	ABBREVIATIONS
Ruine / abandoned	Small wadi	<b>VG</b> Vegetation	<b>EFF</b> Collapsed
Fort / castle	Large wadi	<b>L/R</b> Left and Right	<b>ORN</b> Ruts
Cemetery	Sandy wadi	<b>R/L</b> Right and Left	<b>BAD</b> Bad
Village	River (water)	<b>onL</b> On left	<b>RP</b> Rejoin
Bivouac	Lake / puddle	<b>onR</b> On right	<b>BTW</b> Between
Tunnel	Plain / chott	<b>kpL</b> Keep to the left	<b>MODIF</b> Modification from Opening Car
Pipeline	Towards / direction	<b>kpR</b> Keep to the right	<b>NEW NOTE</b> New note from Opening Car
Wall	Road works	<b>kpS</b> Keep straight	<b>BIG SMALL FOLLOW</b> Written as text (English)
Native / local camp	Reset / recal trip	<b>-V</b> Less visible*	
Patrol station & type of fuel	Distance	<b>±V</b> More/less visible	
Monument	<b>DUNES / SAND</b>	<b>ALT</b> Alternance	
Animals individual	Sandy plain	<b>/</b> During	
Animals	Big bowl "cuvette"	<b>IN</b> In / into	
Cairn	Sand spit	<b>ET</b> And / next	
Rocks	Dune	<b>A</b> At	
Mountain	Broken dune	<b>CX</b> Stone / stony	
Tree	Dunes	<b>E3</b> Narrow*	
Palm tree	<b>DN</b> Dune	<b>Q'</b> Quit / leave*	
Camel grass	<b>DNX</b> Many dunes	<b>TJS</b> Always	
Vegetation	<b>DNT</b> Small dune "dunette"	<b>NBX</b> Many	
Slope	<b>L1 L2 L3</b> Dunes difficulty level	<b>IMP</b> Imperative	

ANGEL OFFROAD TRAINING



# DANGERS



ANGEL OFFROAD TRAINING

# SPEAK CLEARLY / GIVE SHORT INSTRUCTIONS

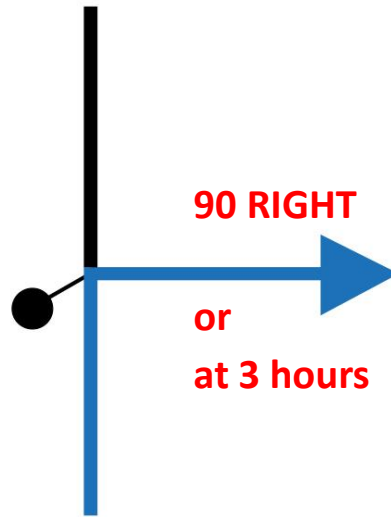
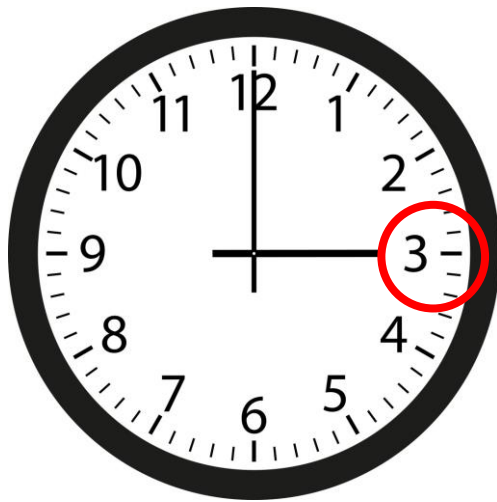

**90 RIGHT**

**or  
at 3 hours**

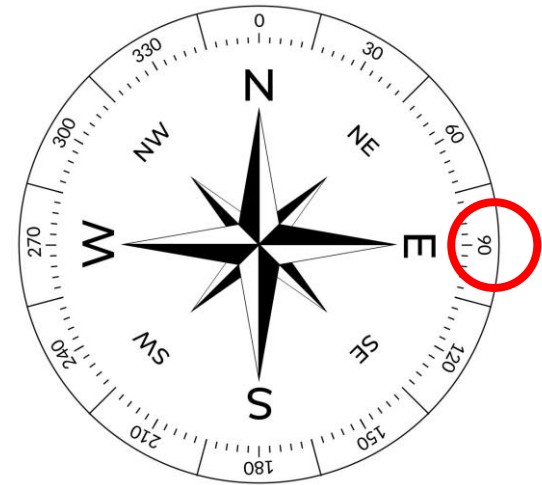

This doesn't mean you are following a 90° cap !

# SPEAK CLEARLY / GIVE SHORT INSTRUCTIONS

What would you say for this one ?

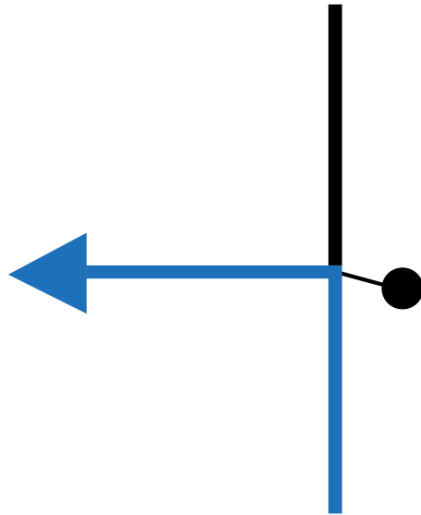

# SPEAK CLEARLY / GIVE SHORT INSTRUCTIONS

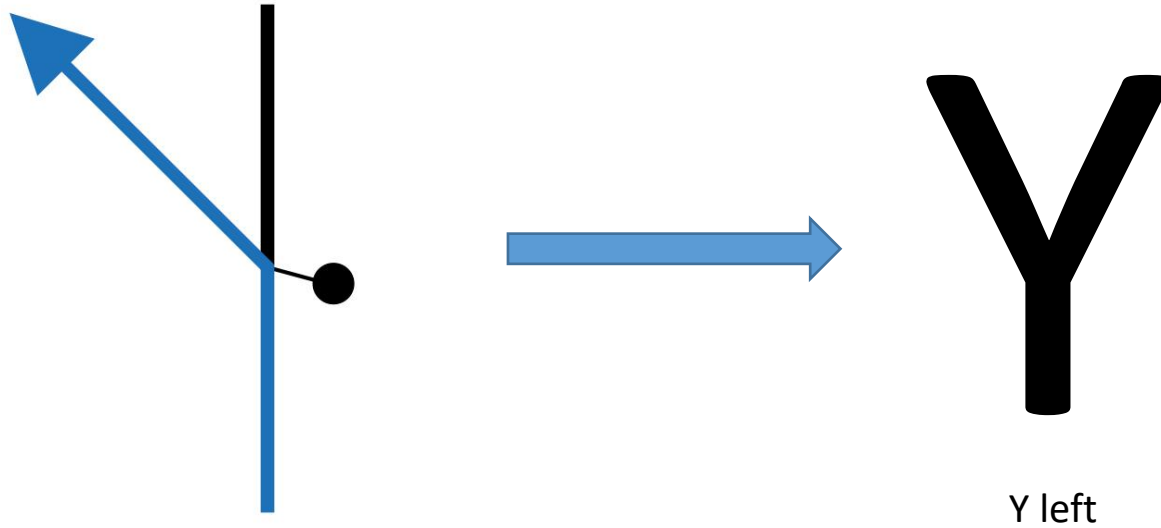

# SPEAK CLEARLY / GIVE SHORT INSTRUCTIONS

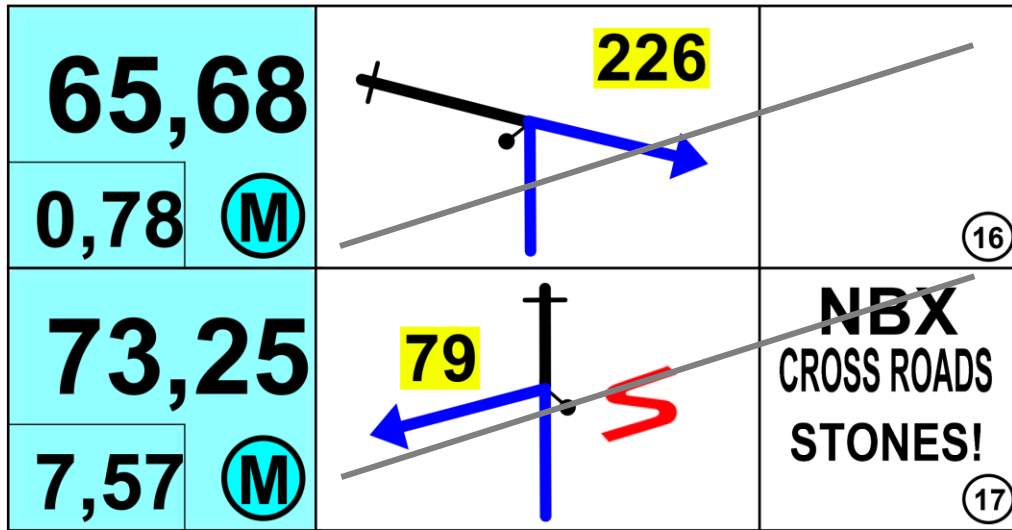

Strike out  
the note  
when you  
pass it

Strike out  
The note  
when you  
pass it



Next note in 7 km

In 1 km waypoint, 90 left at waypoint, twisty, cap 79

In 500 m waypoint, 90 left at waypoint, cap 79, cross many roads, stones, twisty

Repeat every 100 m

**Check that WPM is validated + cap is 79° after turn**

# SPEAK CLEARLY / GIVE SHORT INSTRUCTIONS

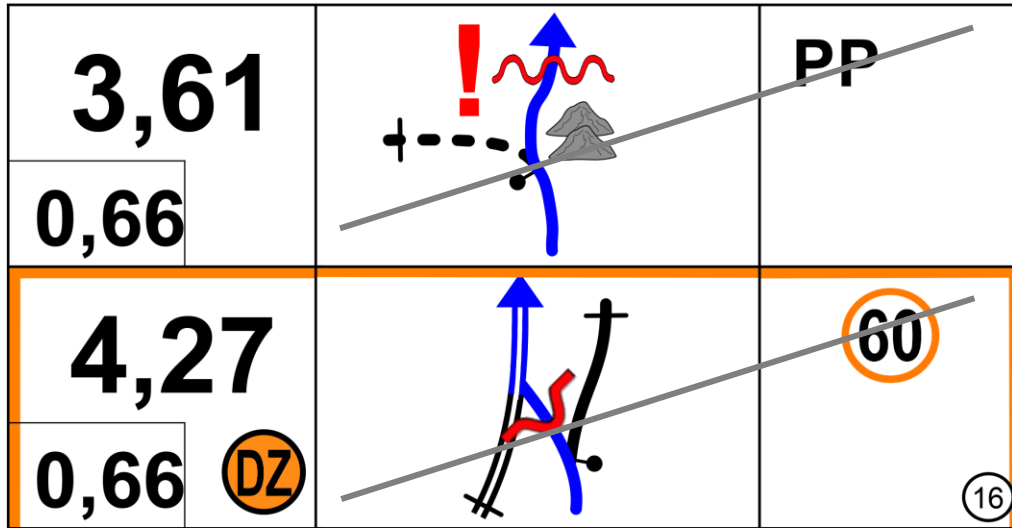

Strike out  
the note  
when you  
pass it

Strike out  
the note  
when you  
pass it

In 600 meters, speed zone 60, Y left at speed zone  
Dip hole  
and rejoin tarmac road on right

# SPEAK CLEARLY / GIVE SHORT INSTRUCTIONS

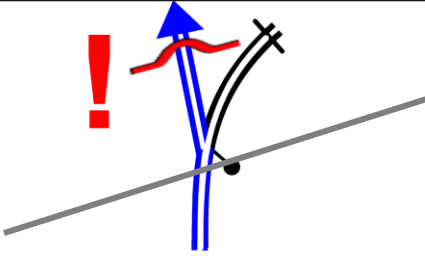
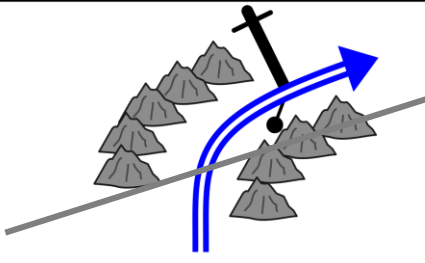
<p><b>4,98</b></p> <p><b>0,71</b></p>		
<p><b>7,18</b></p> <p><b>2,20</b></p>		

← Strike out the note when you pass it

← Strike out the note when you pass it

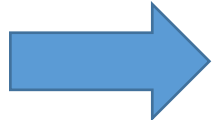

Next note in 2 km  
In 1 km, oblique right between mountains and Y right  
stay on tarmac road

# SPEAK CLEARLY / GIVE SHORT INSTRUCTIONS

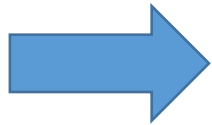

<b>14,94</b>		
<b>1,31</b> ↓		
<b>15,22</b>		<b>PP</b>
<b>0,28</b>		



Strike out  
the note  
when you  
pass it

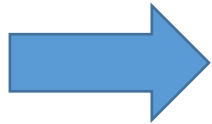

Strike out  
the note  
when you  
pass it

At fence : danger level 2

Y left between soil slopes, and 90 right, twisty

In 300 m : at fence, Y right and Y left on main track



# PREPARE YOUR ROADBOOK

You will receive the roadbook for the next day's stage the day before.

You have time to make some checks :

- Check that no page is missing
- and that they are in the right order
  
- Even if the roadbook is already in color, I suggest you highlight directions
- Make corrections if they are some

# COMMUNICATION IN THE TEAM

## CO-DRIVER

---

- Don't announce a note too early  
Driver won't remember it
- Announce a note 1 km before
  - repeats it 500 m before
  - then every 100 m
- Be clear : use words that both of you understand clearly

## DRIVER

---

- Train your eyes with distances  
Download an odometer app
- Confirm that you saw the note announced by the co-driver

Communication is part of the success

# AVERAGE SPEED CHALLENGES

## - ASC -

# AVERAGE SPEED : WHAT IS IT ?

## How it works ?

- Drive at an average speed between 2 virtual control points marked in the roadbook
- Pay attention to regularity and navigation
- Be at the average imposed at the timed place
- 1 or more average speed challenges in the same day
- Stella device calculates the average speed maintained

## Important to know

- Car odometers are not accurate
- Setting the cruise control is not going to work !

## Tools

- Roadbook
- Stabilos
- Stopwatch
- Calculator
- Stella device

# PREPARE YOUR ROADBOOK

1		RALLY JAMEEL / DAY 1 / SS 1	Km : 123
0,00			Average Speed Stage START
0,00			Average speed 50 km/h <span style="border: 1px solid black; border-radius: 50%; padding: 2px;">1</span>
1,26			PP
1,26			
1,87			PP
0,61			FOLLOW FENCE
<u>2,63</u>			
0,76			
4,03			
1,40	<span style="border: 1px solid black; border-radius: 50%; padding: 2px;">M</span>		<span style="border: 1px solid black; border-radius: 50%; padding: 2px;">2</span>

00 : 01 : 30.72

50 km → 1 hour  
60 minutes  
3600 seconds

1,26 km → t = ?

$$t = \frac{3600 \times \text{distance to travel}}{\text{official average speed}}$$

$$t = \frac{3600 \times 1,26 \text{ km}}{50 \text{ kph}} = 90.72 \text{ seconds}$$

Conversion in hh:mm:ss

60 s = 1 min

+ 90.72 s - 60 s = 30.72 s

# TSD EQUATIONS

$$T \text{ (time)} = D / S$$

$$S \text{ (speed)} = D / T$$

$$D \text{ (distance)} = S \times T$$

# COMMUNICATION IN THE TEAM

## CO-DRIVER

---

- Constantly juggles between the roadbook, the Stella and the stopwatch
- Announce the average speed to maintain
- Announce next note 1 km before
  - repeats it 500 m before
  - then every 100 m
- Inform the pilot of the advance or delay.

## DRIVER







---

- Monitors average speed
- Report all visible intersections as soon as possible.



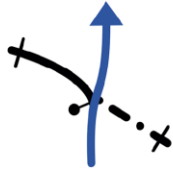

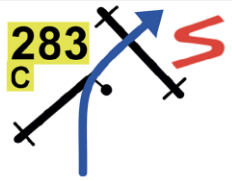

Communication is part of the success

# AVERAGE SPEED CHALLENGE EXERCICE

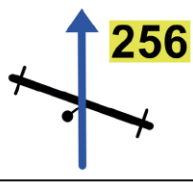
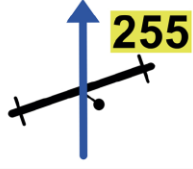

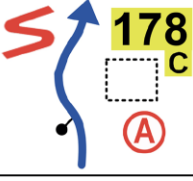
11	RALLY JAMEEL TRAINING / ASC	Km : 94,44
53,13		Average Speed Stage START 
1,03 (M)		Average speed 50 km/h (16)
53,90		P//
0,77		
54,17		PP
0,27		
54,86		PP
0,69 (M)		Average speed 38 km/h (17)
56,11		P//
1,25		

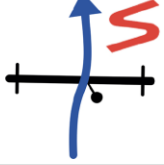
Next 0,48

12	RALLY JAMEEL TRAINING / ASC	Km : 94,44
56,59		P// PP
0,48		
56,91		
0,32		
57,33		Average speed 45 km/h (18)
0,42 (M)		
57,81		
0,48		
58,75		Average Speed Stage FINISH 
0,94 (M)		(19)

Next 0,68

# SOLUTION

ANGEL OFFROAD TRAINING

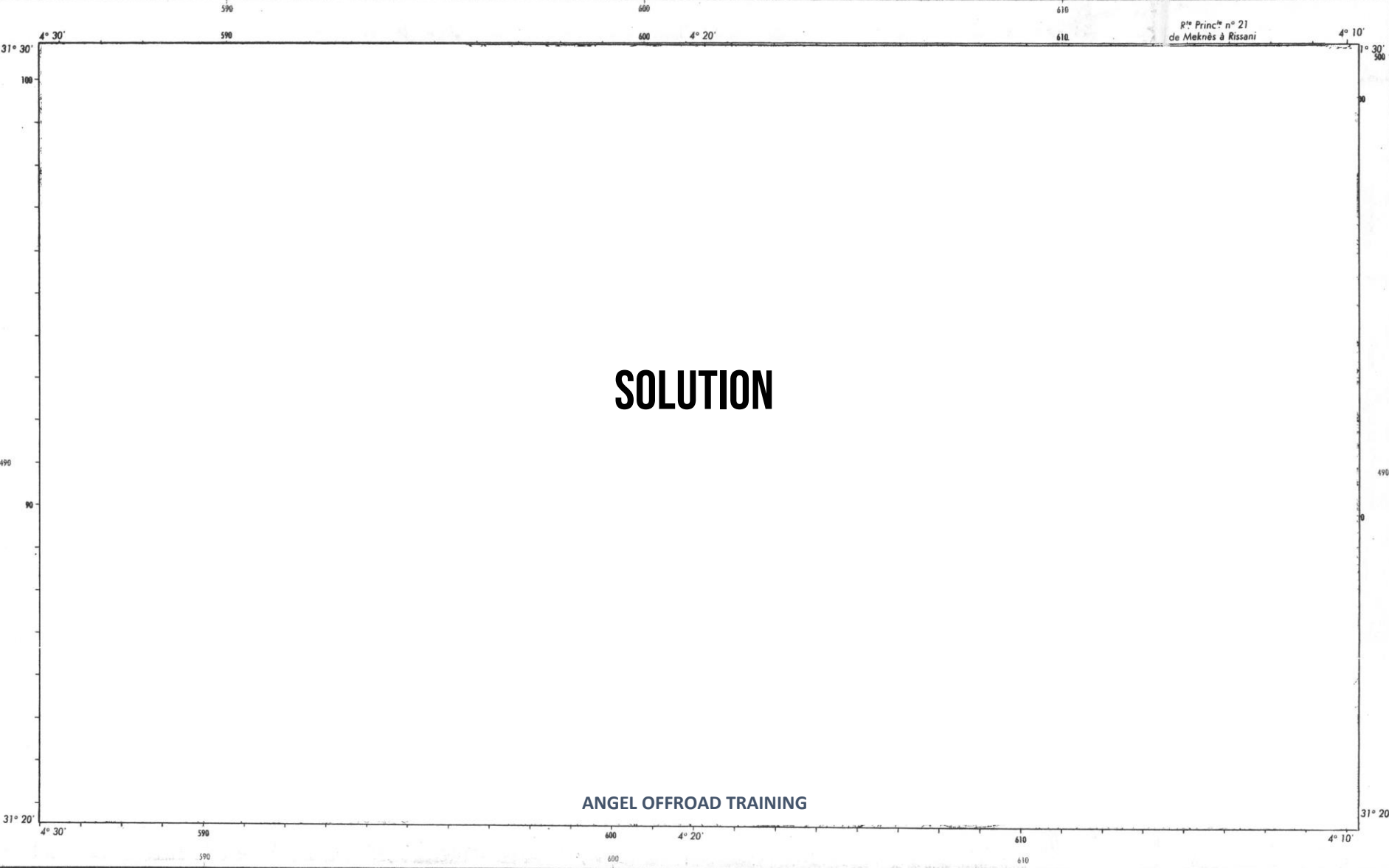

11 RALLY JAMEEL TRAINING / ASC Km : 94,44

53,13  
1,03 (M)

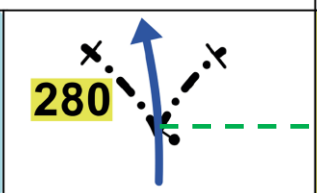

Average Speed  
Stage  
START   
Average speed  
50 km/h (16)

00 : 00 : 00

53,90  
0,77

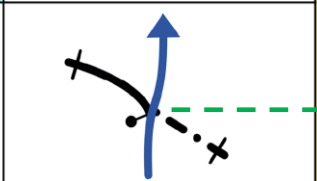

P//

00 : 00 : 55

54,17  
0,27

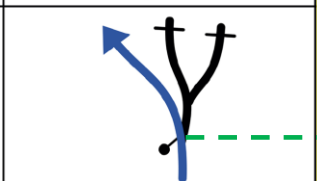

PP

00 : 01 : 15

54,86  
0,69 (M)

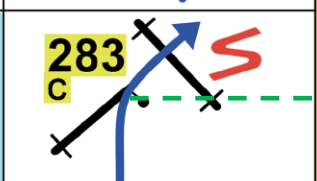

PP  
Average speed  
38 km/h

00 : 02 : 05

Km 55: 00 : 02 : 18

56,11  
1,25

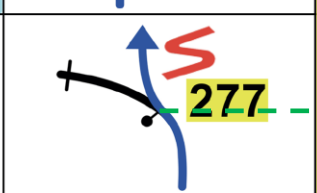

P//

00 : 04 : 03

Next 0,48

12 RALLY JAMEEL TRAINING / ASC Km : 94,44

56,59  
0,48

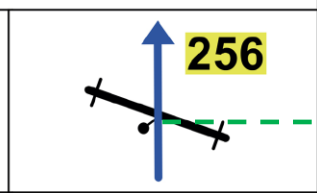

P//  
PP

00 : 04 : 48

56,91  
0,32

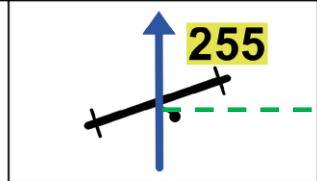

00 : 05 : 19

57,33  
0,42 (M)

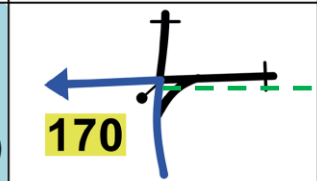

Average speed  
45 km/h (18)

00 : 05 : 59

57,81  
0,48

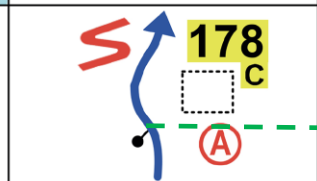

(19)

00 : 06 : 37

Km 58 : 00 : 06 : 52

58,75  
0,94 (M)

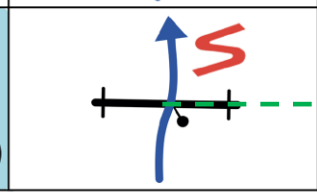

Average Speed  
Stage  
FINISH (19)

00 : 07 : 52

Next 0,68

# MANAGE YOUR TIME

# TIME CARD

- Carried by the co-driver
- The time card is a record of stage times and time control arrival times
- Stamped by officials
- Provides proof in case of a dispute
- Use it to manage your timing

DO NOT LOOSE IT !

		Section <b>2</b>	Leg 2	#CarNo.
From TC1B HAIL Service OUT - Start Leg 2				
To TC2A QASSIM, Service Park Service IN *				

TC1B HAIL Service OUT - Start Leg 2

RS3 238.39 KM

TC2 Start S.S. Qassim

Actual Time

Target Time **02 38**

Competitor Use

+5 Minutes

Finish SS2 Qassim

A SS2  
Finish SS2

SS2" Qassim "

SS2 A 91.20 KM

Max Time 3:00

D SS2  
Start SS2

Provisional Time

Net Time

RS4 119.23 KM

TC2A QASSIM, Service Park  
Service IN \*

Competitor Use

Target Time **01 30**

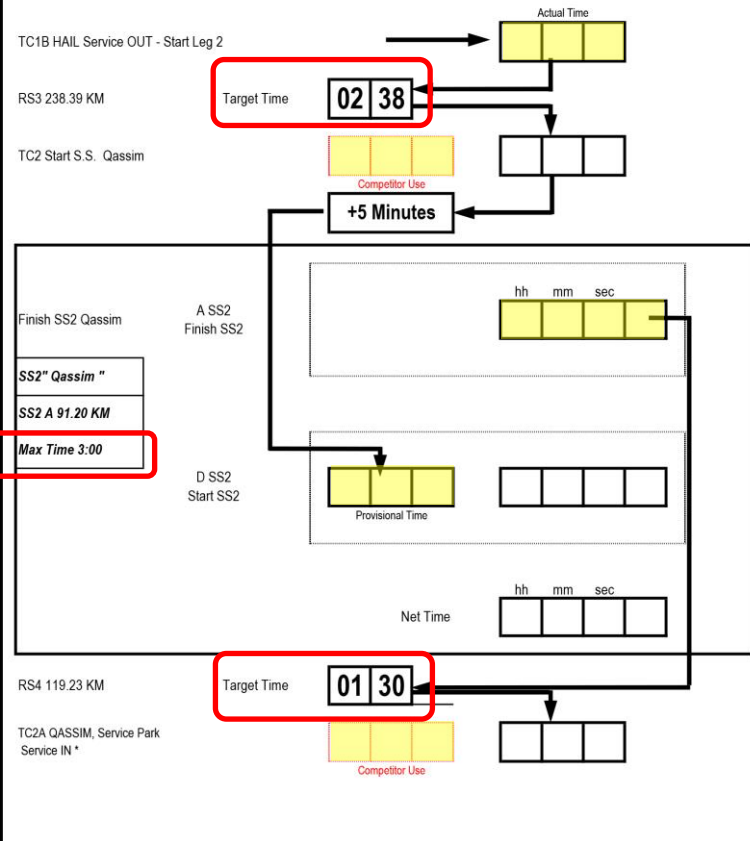

	Section	Leg 2	#Car.No.
	2	From TC1B HAIL Service OUT - Start Leg 2	
		To TC2A QASSIM, Service Park Service IN *	

ROAD SECTION A

SELECTIVE SECTION

ROAD SECTION B

TO BE FILL BY THE COMPETITORS (OPTIONAL)

\* MEANS THAT YOU CAN ARRIVE EARLIER AT SERVICE PARK

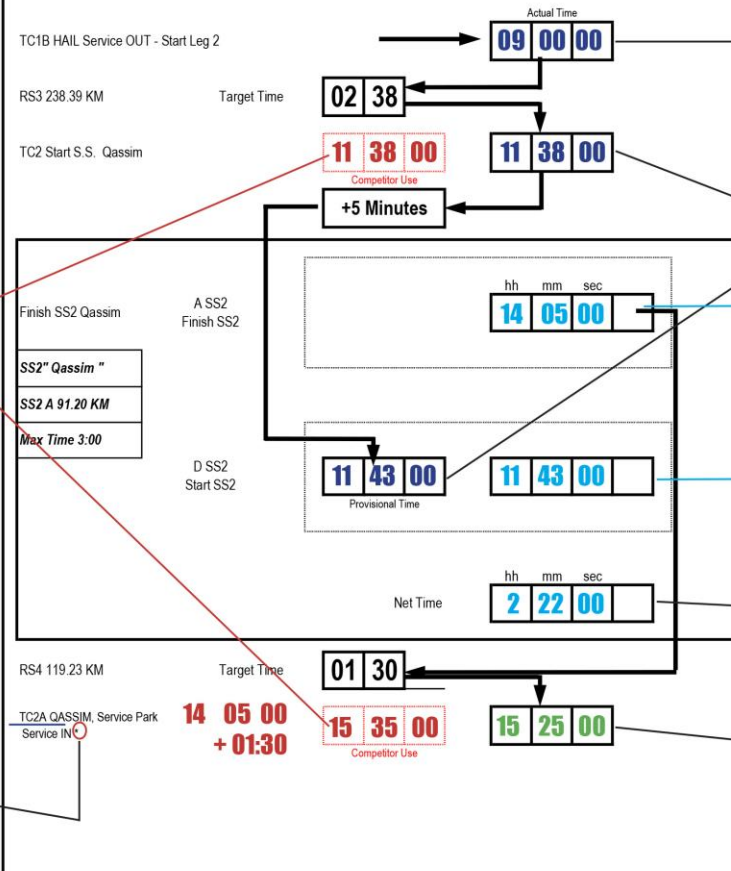

START FROM BIVOUAC  
HH:MM:SS

FILL BY SAME  
MARSHAL

ACTUAL FINISH TIME  
FILL BY STOP MARSHAL  
AT ASS

ACTUAL START TIME  
FILL BY START  
MARSHAL AT DSS

$$\begin{array}{r}
 14\ 05\ 00 \text{ Finish time} \\
 - 11\ 43\ 00 \text{ Start time} \\
 \hline
 = 2\ 22\ 00
 \end{array}$$

ACTUAL ARRIVAL  
TIME AT BIVOUAC  
FILL BY SERVICE  
PARK MARSHAL

# START PROCEDURE

EXAMPLE : START TIME OF SELECTIVE SECTION AT 11H43

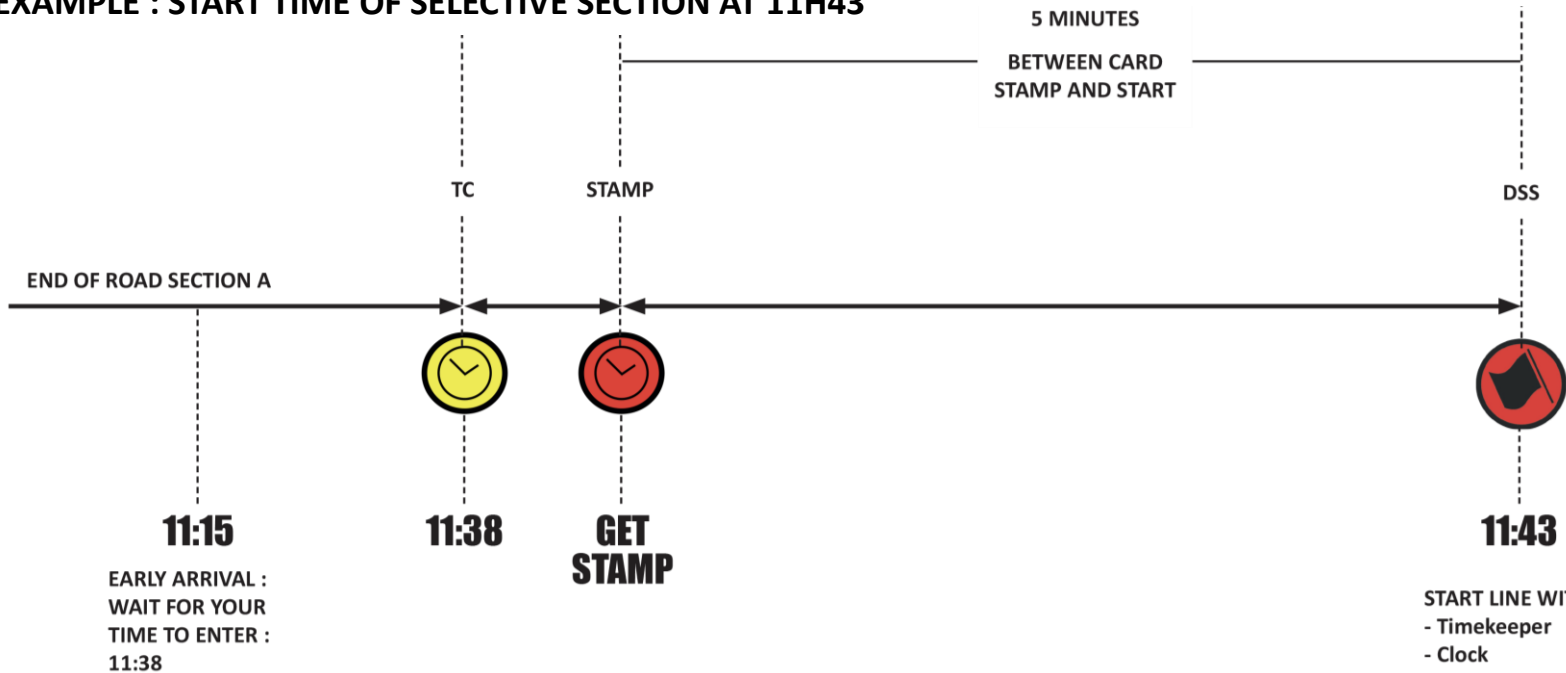

In case you arrive just on time and you can not reach the Time Control (yellow panel) because of any road blocking in front of you, walk to the Marsall with your Time Card to get your stamp, and ask him to open the road for you and get your card stamp.

# NAVIGATOR BAG

Essential tools for the co-driver :

- Notebook
- Calculator
- Highlighters
- Pens & pencils
- Permanent maker
- White labels
  
- Stopwatch





# SPORTITY

ANGEL OFFROAD TRAINING

# OFFICIAL NOTICE BOARD



*Sportity*

For direct event information please download  
the Sportity app and insert this password:

**JAMEEL23**

[www.sportity.com](http://www.sportity.com)

Sportity app is available in



ANGEL OFFROAD TRAINING

# HOMework FOR DAY 2

# ROAD BOOK READER APP



**Rally Roadbook Reader** (4+)  
Rally Navigator Mobile App  
Rally Navigator, LLC  
Designed for iPad  
★★★★ 4.0 • 3 Ratings  
Free  
[View in Mac App Store ↗](#)



**Rally Blitz Navigator Pro** (4+)  
PepeRico, LLC  
Designed for iPad  
Free - Offers In-App Purchases  
[View in Mac App Store ↗](#)

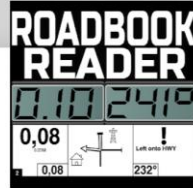

Rally Roadbook Reader  
Rally Navigator

Choisir un appareil

**RALLY NAVIGATOR**

**RALLY ROADBOOK READER**

0.10	08:48	242°
0.00	0.00	13.37
0.00	13.20	11.79

**CROSS COUNTRY RALLY**

0.10	241°	
0.00	0.00	1.58
0.08	1.50	

**ROAD & STAGE RALLY**



00.38 Kilometers

047° Location accuracy is 1.3 meters

0.00	START	Follow road West
0.72	LT	
1.90	CAP 110°	Cross Big Wash

ANGEL OFFROAD TRAINING

**WORK AS A TEAM  
AND HAVE FUN**



**ANGEL OFFROAD TRAINING**